

General Safety Information

⚠ WARNING – To avoid serious injuries:

- Improper use of your bicycle's brake system may result in a loss of control or an accident, which could lead to a severe injury. Because each bicycle may handle differently, be sure to learn the proper braking technique (including brake lever pressure and bicycle control characteristics) for your bicycle. Consult your bicycle dealer and the bicycle's owners manual, and practice your riding and braking technique.
- Use the ST-6700/6703, BL-TT79 with the BR-6700. Do not use the BR-6700 in combination with previous STI levers for road riding or with the BL-R770/BL-R550 brake levers for flat handlebars, otherwise the braking performance provided will be much too strong.
- Securely tighten the caliper brake mounting nuts to the specified tightening torque.
 - Use lock nuts with nylon inserts (self-locking nuts) for nut-type brakes.
 - For sunken nut type brakes, use sunken nuts of the appropriate length which can be turned six times or more; when re-installing, apply sealant (locking adhesive) to the nut threads.
- If the nuts become loose and the brakes fall off, they may get caught up in the bicycle and the bicycle may fall over. Particularly if this happens with the front wheel, the bicycle may be thrown forward and serious injury could result.
- Brakes designed for use as rear brakes should not be used as front brakes.
- Because of the characteristics of the carbon fiber material, you must never modify the levers, otherwise the lever may break and the brakes may no longer work as a result.
- Before riding the bicycle, check that there is no damage such as carbon fiber peeling or cracking. If there is any damage, replace with a new part immediately without trying to repair the damage, otherwise the lever may break and the brakes may no longer work as a result.
- Obtain and read the service instructions carefully prior to installing the parts. Loose, worn or damaged parts may cause the bicycle to fall over and serious injury may occur as a result. We strongly recommend only using genuine Shimano replacement parts.
- Be careful not to allow any oil or grease to get onto the brake shoes. If any oil or grease do get on the shoes, you should replace the shoes, otherwise the brakes may not work correctly.
- Check the brake cable for rust and fraying, and replace the cable immediately if any such problems are found. If this is not done, the brakes may not work correctly.
- Always make sure that the front and rear brakes are working correctly before you ride the bicycle.
- The required braking distance will be longer during wet weather. Reduce your speed and apply the brakes early and gently.
- If the road surface is wet, the tires will skid more easily. If the tires skid, you may fall off the bicycle. To avoid this, reduce your speed and apply the brakes early and gently.
- Read these Technical Service Instructions carefully, and keep them in a safe place for later reference.

Note

- Use a soft cloth to clean the carbon fiber levers, and be sure to moisten the cloth with neutral detergent before using it, otherwise the lever material may become damaged and lose its strength.
- Avoid leaving the carbon fiber levers in places where high temperatures are present. Also keep them well away from fire.
- If using SHIMANO's road brake shoes in combination with ceramic rims, the brake shoes will wear more quickly than normal.
- If the brake shoes have worn down until the grooves are no longer visible, they should be replaced.
- Parts are not guaranteed against natural wear or deterioration resulting from normal use.
- For maximum performance we highly recommend Shimano lubricants and maintenance products.
- For any questions regarding methods of handling or maintenance, please contact the place of purchase.

In order to realize the best performance, we recommend that the following combination be used.

| | |
|---------------|--|
| Series | ULTEGRA |
| Brake lever | ST-6700 / 6703, BL-TT79 |
| Caliper Brake | BR-6700 |
| Brake cable |  |

Installation of the brake lever

1. Installation to the handlebar

Move the bracket cover forward, and then securely tightening the mounting nut with a 5 mm Allen key.

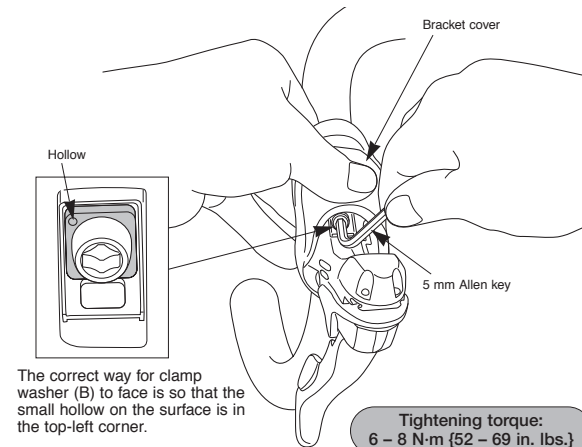

The correct way for clamp washer (B) to face is so that the small hollow on the surface is in the top-left corner.

When installing the components to carbon frame/handle bar surfaces, verify with the manufacturer of the carbon frame/parts for their recommendation on tightening torque in order to prevent over tightening that can cause damage to the carbon material and/or under tightening that can cause lack of fixing strength for the components.

2. Installation of the brake cable

Loosen the screw and remove the name plate.

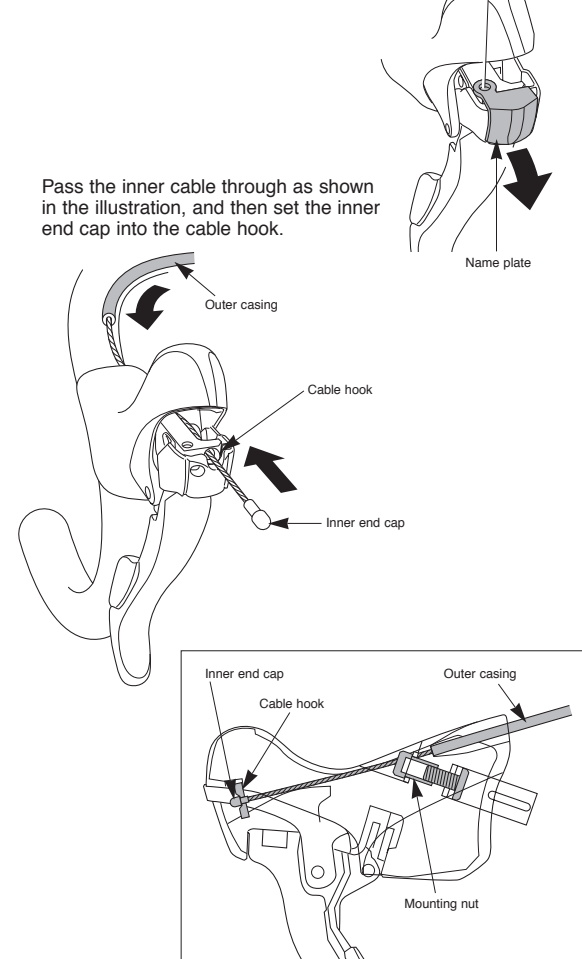

Pass the inner cable through as shown in the illustration, and then set the inner end cap into the cable hook.

Temporarily secure the outer casing to the handlebar (by using tape or similar material).

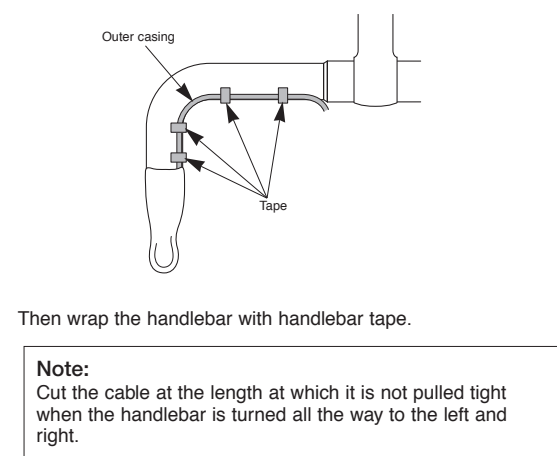

3. Install the name plate.

Tightening torque:
0.15 - 0.2 N·m {1.3 - 1.8 in. lbs.}

4. Lever stroke adjustment (ST-6700/6703)

If you would like to make the lever stroke smaller, install the accessory pad spacer. Check the brake operation while adjusting.

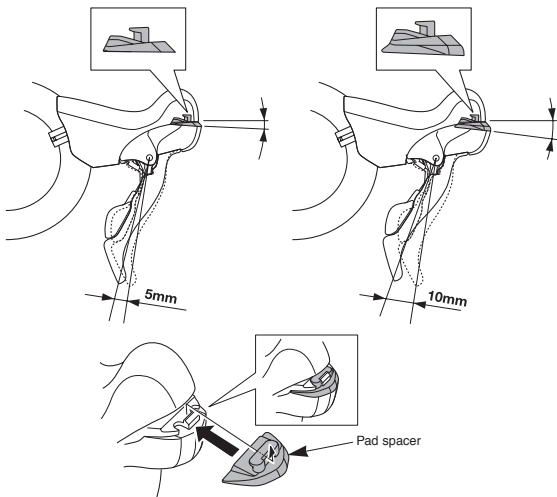

Installation of the brake

1. Installation of the brake itself

Compress the arch, and set while the shoe is in firm contact with the rim.

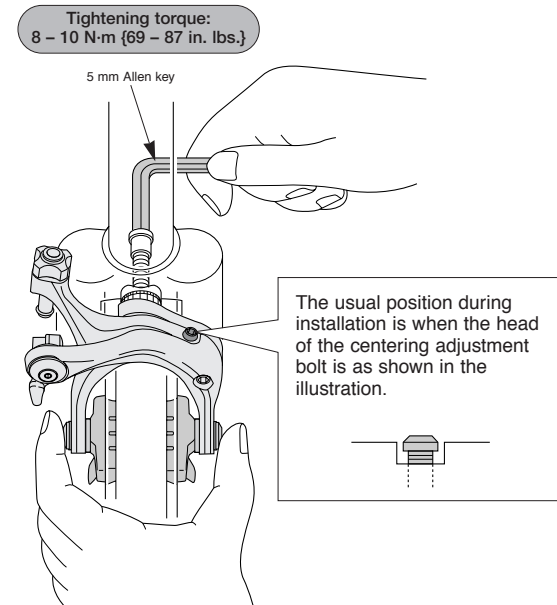

The usual position during installation is when the head of the centering adjustment bolt is as shown in the illustration.

2. Brake shoe setting position

After adjusting the brake shoe position so that the shoe surface and the rim surface are as shown in the illustration, tighten the shoe fixing bolt.

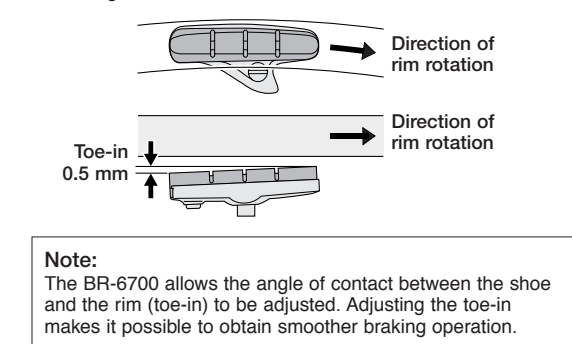

Note:

The BR-6700 allows the angle of contact between the shoe and the rim (toe-in) to be adjusted. Adjusting the toe-in makes it possible to obtain smoother braking operation.

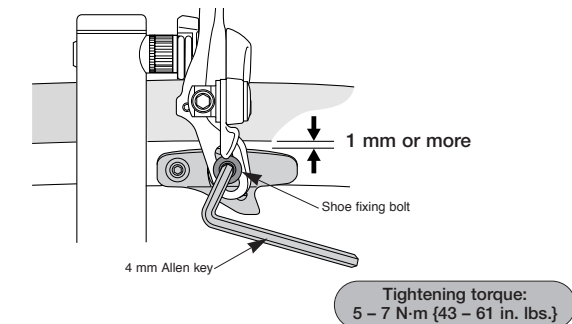

3. Cable connection

Set the quick release lever to the closed position; then adjust the shoe clearance (as shown in the illustration below) and secure the cable.

Cable bolt tightening torque:
6 - 8 N·m {52 - 69 in. lbs.}

4. Centering of the brake shoe

Make a minor adjustment by using the centering adjustment bolt.

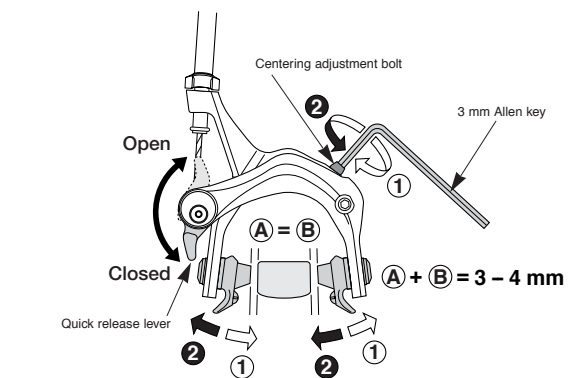

5. Readjustment of the shoe clearance

Turn the cable adjustment nut to readjust the shoe clearance.

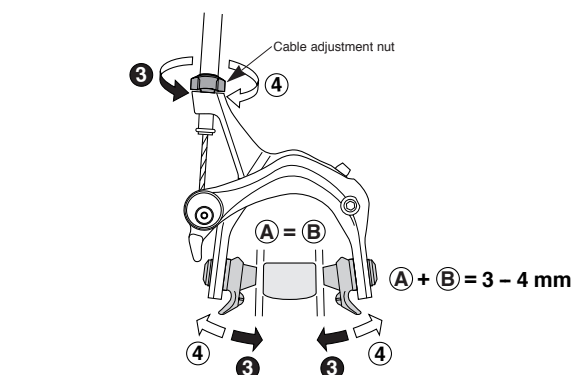

6. Check

Depress the brake lever about 10 times as far as the grip and check that everything is operating correctly and that the shoe clearance is correct before using the brakes.

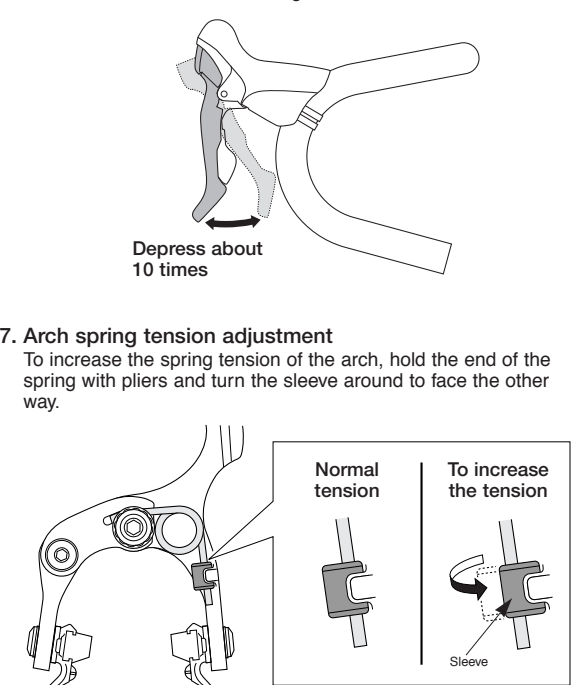

Replacement of the cartridge shoe

1. Remove the fixing bolt.

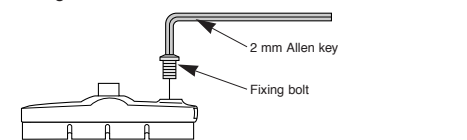

2. Remove the shoe by sliding it along the groove of the shoe holder.

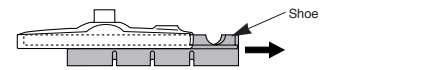

3. There are two different types of shoe and shoe holder to be used in the left and right positions respectively. Slide the new shoes into the grooves on the shoe holders while taking note of the correct directions and bolt hole positions.

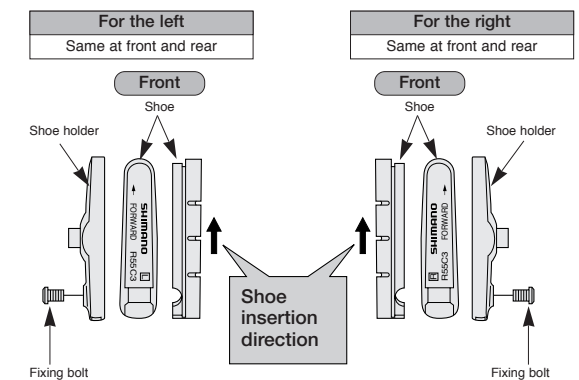

4. Tighten the fixing bolt.

Tightening torque:
1 - 1.5 N·m {9 - 13 in. lbs.}

SHIMANO

SHIMANO AMERICAN CORPORATION
One Holland, Irvine, California 92618, U.S.A. Phone: +1-949-951-5003

SHIMANO EUROPE B.V.
Industrieweg 24, 8071 CT Nunspeet, The Netherlands Phone: +31-341-272222

SHIMANO INC.
3-77 Oimatsu-cho, Sakai-ku, Sakai-shi, Osaka 590-8577, Japan

Please note: specifications are subject to change for improvement without notice. (English)
© Mar. 2009 by Shimano Inc. XBC IZM Printed in Japan.

